

CABLE LENGTH SHOWN NOT TO SCALE

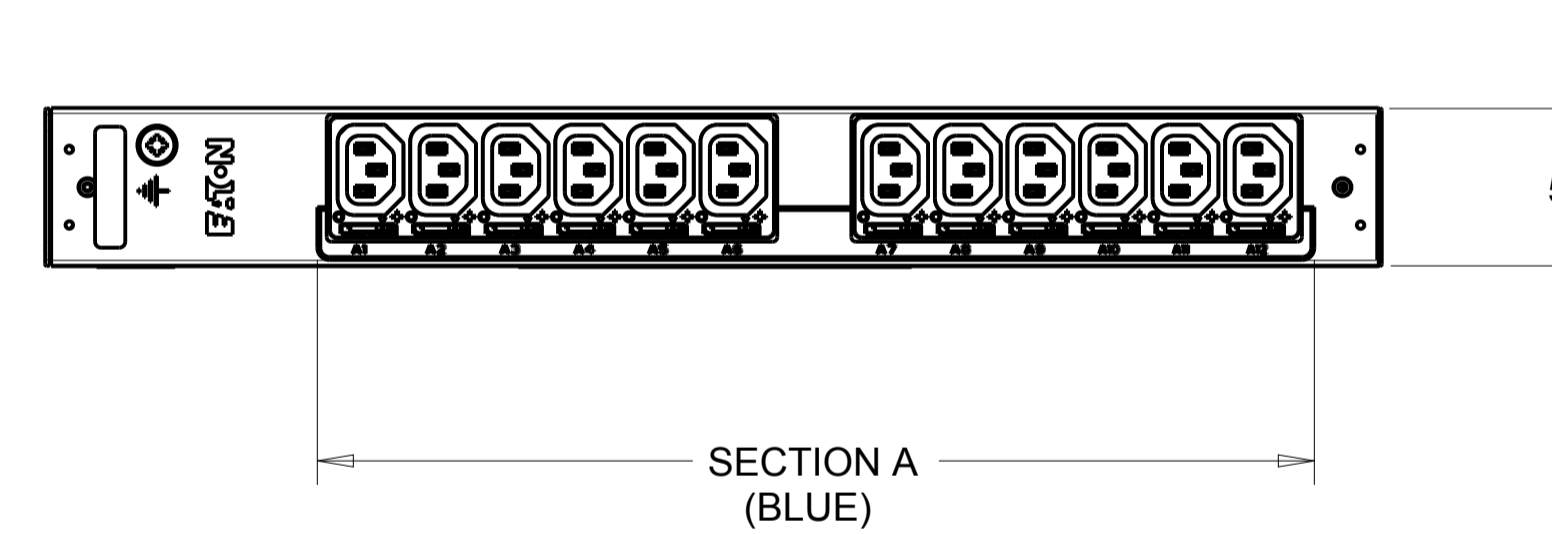

CIRCUIT SCHEMATIC

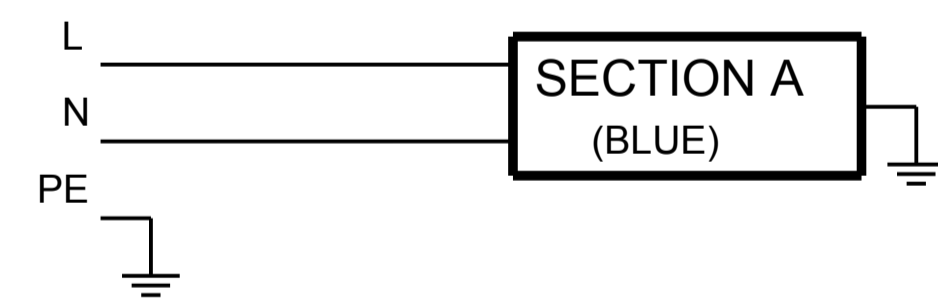

## EBAB19 G3 BASIC

FUNCTIONALITY	INPUT	OUTPUT	ENVIRONMENTAL
NONE	1Ø; 200-240V~; W+N+PE 50/60Hz 10A	(12) IEC 60320 C13 GRIP	0 TO 60 °C
MECHANICAL	INPUT RATING	OUTPUT RATING	CERTIFICATIONS
LENGTH: 443MM WIDTH: 52 MM DEPTH: 53MM ALUMINIUM CHASSIS, BLACK MNT PATTERN SK-23919-Y1	IEC 60309 C14 10A 230V~ W+N+PE 1.5MM HO5 POWER CORD CABLE LENGTH: 3.0 M	200-240V~; 50/60Hz 10A PER C13 10A MAX TOTAL	CE, CB
CIRCUIT BREAKERS	FILTER AND SPIKE/SURGE	ACCESSORIES	CONFIGURATION
NONE	NONE	STANDARD KSP018 - HOR INSTALLATION PACK OPTIONAL EMP001 - ENVIRONMENTAL PROBE	EBA3CP8FABC71AM

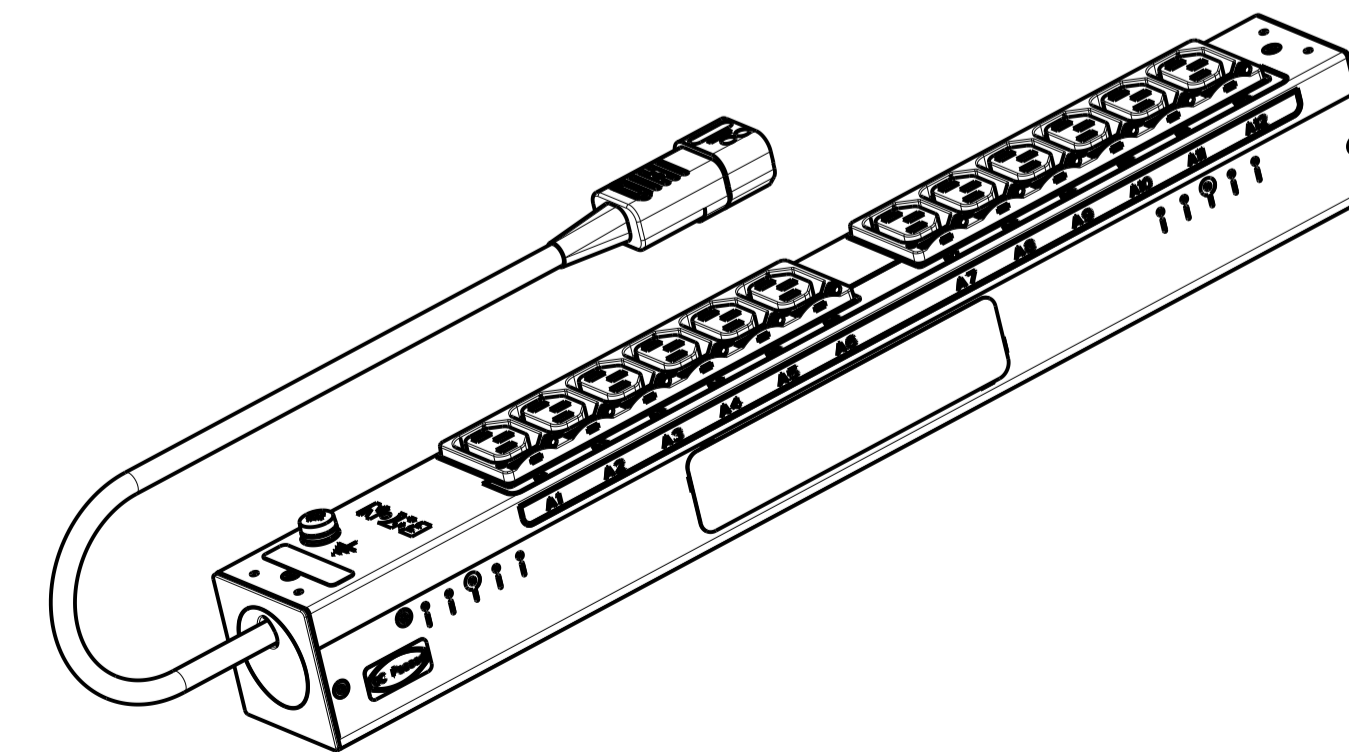

PICTORIAL VIEW  
SCALE 0.400

REV	MODIFICATION	DATE	DESIGNER	VERIF.
00	INITIAL RELEASE	13.05.2014	RA	MB
		HEINEMANN PRODUCTS		VUE/VIEW 1ST VIEW
CH-1345 LE LIEU SWITZERLAND		ECHELLE / SCALE 4/10		N° MAG EBAB19
TRAITEMENT / FINISH N/A		VERIFIE PAR / VERIFIED BY MB		DESSINE LE / DRAWED THE 13.05.2014
MATERIE / MATERIAL N/A		NIVEAU DU CERTIFICAT DE SOUMISSION REQUIS / SAMPLES APPROVAL PROCESS REPORT N/A		DIMENSIONS AND TOLERANCES IN MILLIMETERS
DESIGNATION EPDU BA 0U (C14 10A 1P)12XC13		NUMERO DU PLAN PLAN NUMBER SK-34819-Y1		REV. 00
COTES A CONTROLER INSPECTION DIMENSIONS XX.XX		COTES FONCTIONNELLES FUNCTIONAL DIMENSIONS # XX.XX		

Ce document est propriété de Eaton Industries Manufacturing GmbH. Duplication interdite sans autorisation.  
This document is Eaton Industries Manufacturing GmbH property. Duplication forbidden without authorization.